

H&S PARTS BOOK

VR1112 RAKE

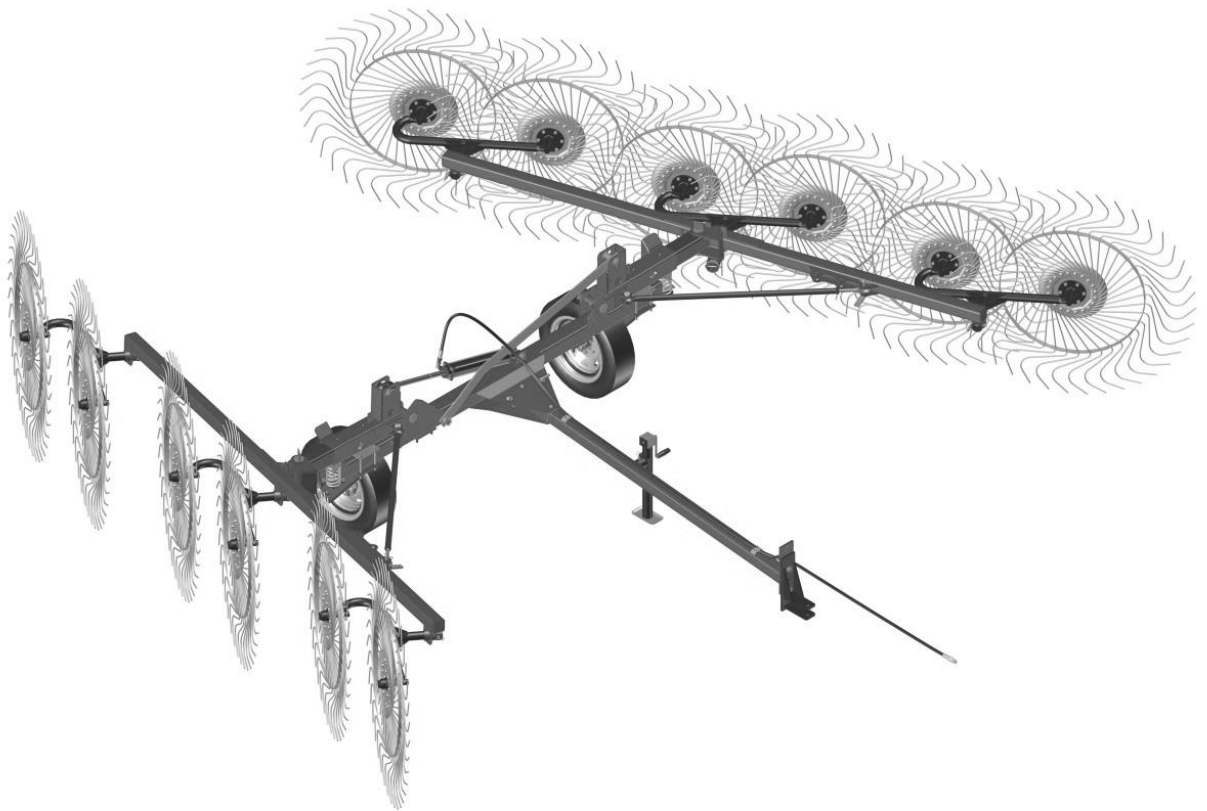

Revision #00
Starting Ser.#613590

Part #69796
HSMF1115

P.O. BOX 768, MARSHFIELD, WI 54449
(715) 387-3414 FAX (715) 384-5463
www.hsmfgco.com

CONTENTS

Instructions For Ordering Parts - About Improvements	1
Figure 1 - Frame Components.	2-3
Figure 2 - Slider and Components.	4-5
Figure 3 - Hub Assembly.	6-7
Figure 4 - Rake Beam and Components.	8-9
Figure 5 - Rake Wheel Assembly.	10-11
Figure 6 - Optional Kicker Wheel.	12-13
Figure 7 - Hydraulics.	14-15
Figure 8 - Hydraulic Cylinder	16-17
Parts Notes.	18

INSTRUCTIONS FOR ORDERING PARTS

All service parts should be ordered through your authorized H&S dealer. They will be able to give you faster service if you will provide them with the following

1. Model & Serial number is located on the left, rear main frame of your unit.
2. All reference to left or right apply to the machine as viewed from the rear.
3. Parts should not be ordered from illustration only. Please order by complete part number.
4. If your dealer has to order parts - give shipping instructions:

VIA truck - large pieces (please specify local truck lines)

VIA United Parcel Service (include full address)

H&S MFG. CO. INC.	
MARSHFIELD, WIS.	
MOD. NO.	<input type="text"/>
SER. NO.	<input type="text"/>
DESCR.	<input type="text"/>

PLEASE RECORD NUMBERS FOR YOUR UNIT FOR QUICK REFERENCE

ABOUT IMPROVEMENTS

H&S IS CONTINUALLY STRIVING TO IMPROVE IT'S PRODUCTS

We must therefore, reserve the right to make improvements or changes whenever it becomes practical to do so without incurring any obligation to make changes or additions to the equipment previously sold.

FIGURE 1
FRAME COMPONENTS

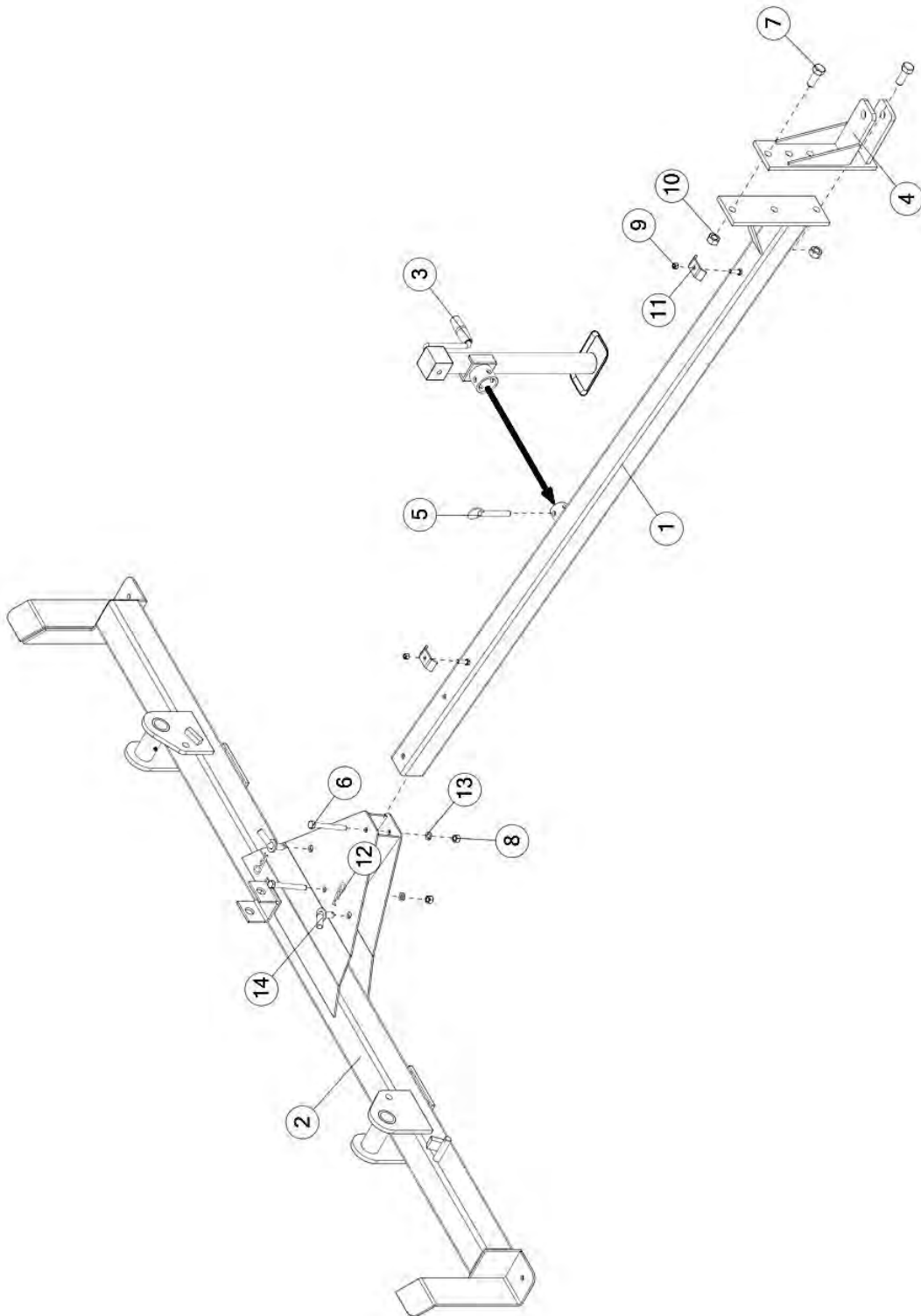

FIGURE 1

FRAME COMPONENTS

<u>ITEM</u>	<u>QTY</u>	<u>PART #</u>	<u>DESCRIPTION</u>
1	1	10WR29	ASSY, POLE
2	1	12WR4	ASSY, MAIN FRAME
3	1	BFR753A	JACK, SIDEWIND,2000#
4	1	10WR30	ASSY, HITCH
5	1	BFR4	PULL PIN
6	2	YBHH16140	BOLT, 1/2 X 4-1/2 GR 5
7	2	YBHH24015	BOLT, 3/4 X 2 GR 5
8	2	YNHX16005	HEX NUT, 1/2
9	2	YNL12005	HEX NUT, TOP LOCK, 3/8-16
10	2	YNL24005	HEX NUT, TOP LOCK, 3/4-10
11	2	23N67	FRONT HOSE BRACKET
12	2	YPHR02010	HAIR PIN
13	2	YWLO16005	WASHER, LOCK, 1/2
14	2	10WR4	PULL PIN

FIGURE 2
SLIDER & COMPONENTS

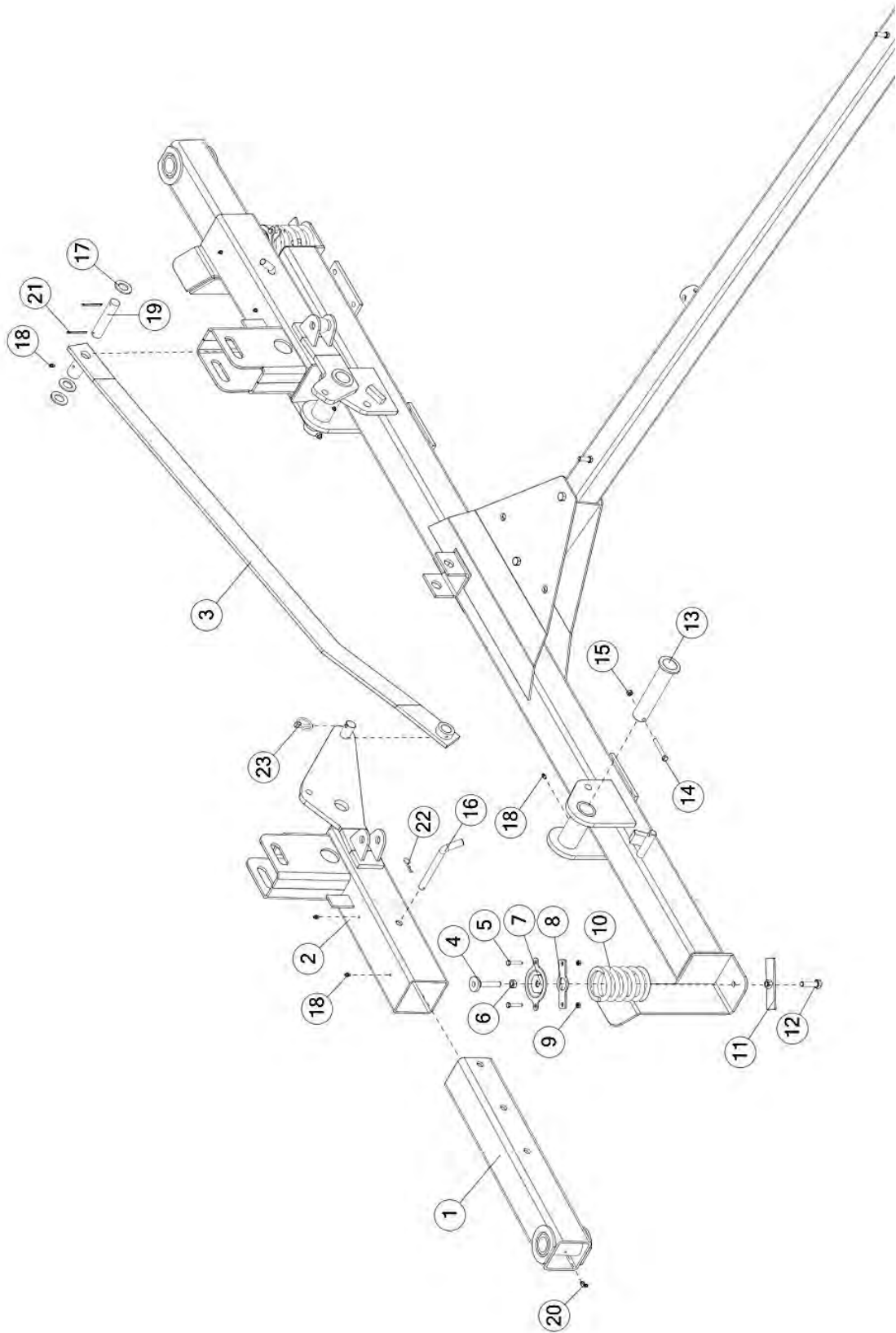

FIGURE 2

SLIDER & COMPONENTS

<u>ITEM</u>	<u>QTY</u>	<u>PART #</u>	<u>DESCRIPTION</u>
1	2	10WR34	WLDMT, SLIDE ARM, RAKE
2	1	10WR27	ASSY, RIGHT LIFTER ARM
*	1	10WR28	ASSY, LEFT PIVOT ARM HOUSING
3	1	12WR5	ASSY, LIFTING LINKAGE
4	2	10WR16	ASSY, SPRING ADJUSTMENT
5	4	YBHH08025	BOLT, 1/4 X 1-1/2 GR 5
6	2	YNJM16005	HEX NUT, JAM, 1/2-13
7	2	10WR15	ASSY, SPRING DISK
8	2	10WR46	SPRING BOTTOM
9	4	YNRL08005	HEX NUT, REVERSIBLE-SIDE LOCK, 1/4-20
10	2	12WR1	SPRING
11	2	10WR3	ASSY, SPRING CLAMP
12	2	YBHH16055	BOLT, 1/2 X 1-3/4 GR 5
13	2	10WR7	ASSY, PIVOT ARM PIN
14	2	YBHH10080	BOLT, 5/16 X 2-1/2 GR 5
15	2	YNHX10020	HEX NUT, 5/16"-18 GR. 8
16	2	10WR14	BENT PIN, 5/8" X 5.00"
17	1	16SV136	WASH, FLAT, 1.75 X 1.02 X 0.13, ZC ZERK,
18	1	G89	1/4"-28 STRAIGHT
19	1	LW55	PIN, 1.00 X 4.50, CYLINDER
20	2	RG21	GREASE ZERK, 45 DEGREE
21	1	YPCT05025	COTTER PIN, 5/32 X 2
22	2	YPHR02005	HAIR PIN
23	1	YPLY08011	LYNCH PIN, 1/4 X 1-9/16

***MEANS NOT SHOWN**

FIGURE 3 HUB ASSEMBLY

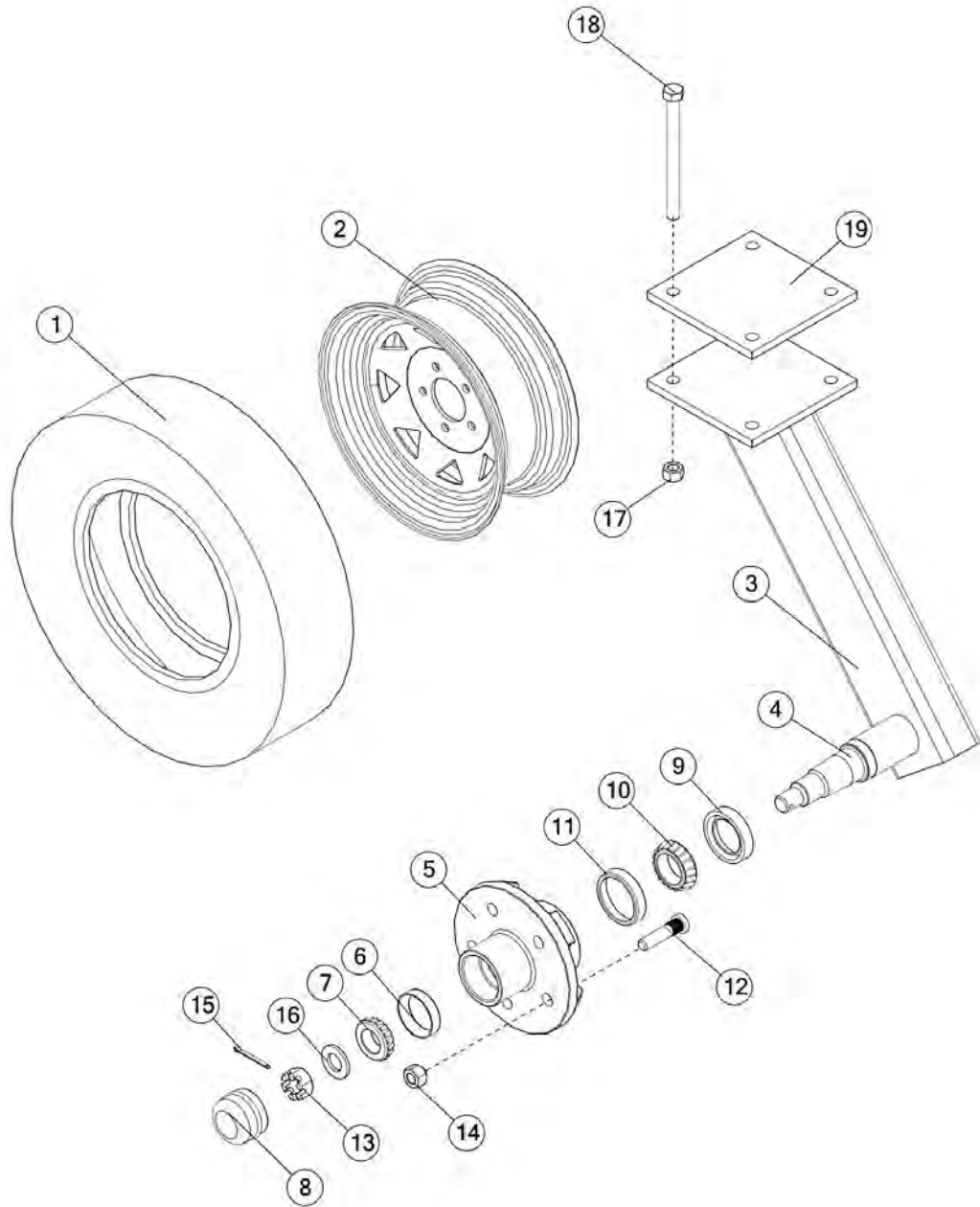

FIGURE 3

HUB ASSEMBLY

<u>ITEM</u>	<u>QTY</u>	<u>PART #</u>	<u>DESCRIPTION</u>
1	2	CAT198	ST175/80D13 LRB TIRE ONLY
2	2	CAT195	WHEEL, 15X6X5.5 -6 BOLT
3	1	10WR33	LEFT AXLE
*	1	10WR32	RIGHT AXLE
4	2	10WR48	SPINDLE
5	2	CAT8	HUB
6	2	BFR275	RACE
7	2	CAT10	OUTER BEARING
8	2	CAT46	CAP, HUB
9	2	CAT5	GREASE SEAL
10	2	CAT6	INNER BEARING
11	2	CAT7	INNER RACE
12	10	YBSD16018	STUD BOLT, 1/2-20 UNF X 2-1/8, 9/16 SHOULDER
13	2	YNSL24010	HEX NUT, SLOTTED, 3/4-16, PLAIN
14	10	YNWL16005	WHEEL NUT, 1/2"-20 UNF
15	2	YPCT05010	COTTER PIN 5/32" X 1-1/2"
16	2	YWFL24010	WASHER, FLAT, SAE 3/4, PLAIN
17	4	YNHX16007	HEX NUT, 1/2"-13 GR. 8
18	4	YBHH16165	BOLT, 1/2 X 6 GR 5
19	2	10WR38	AXLE PLATE

***MEANS NOT SHOWN**

FIGURE 4
RAKE BEAM & COMPONENTS

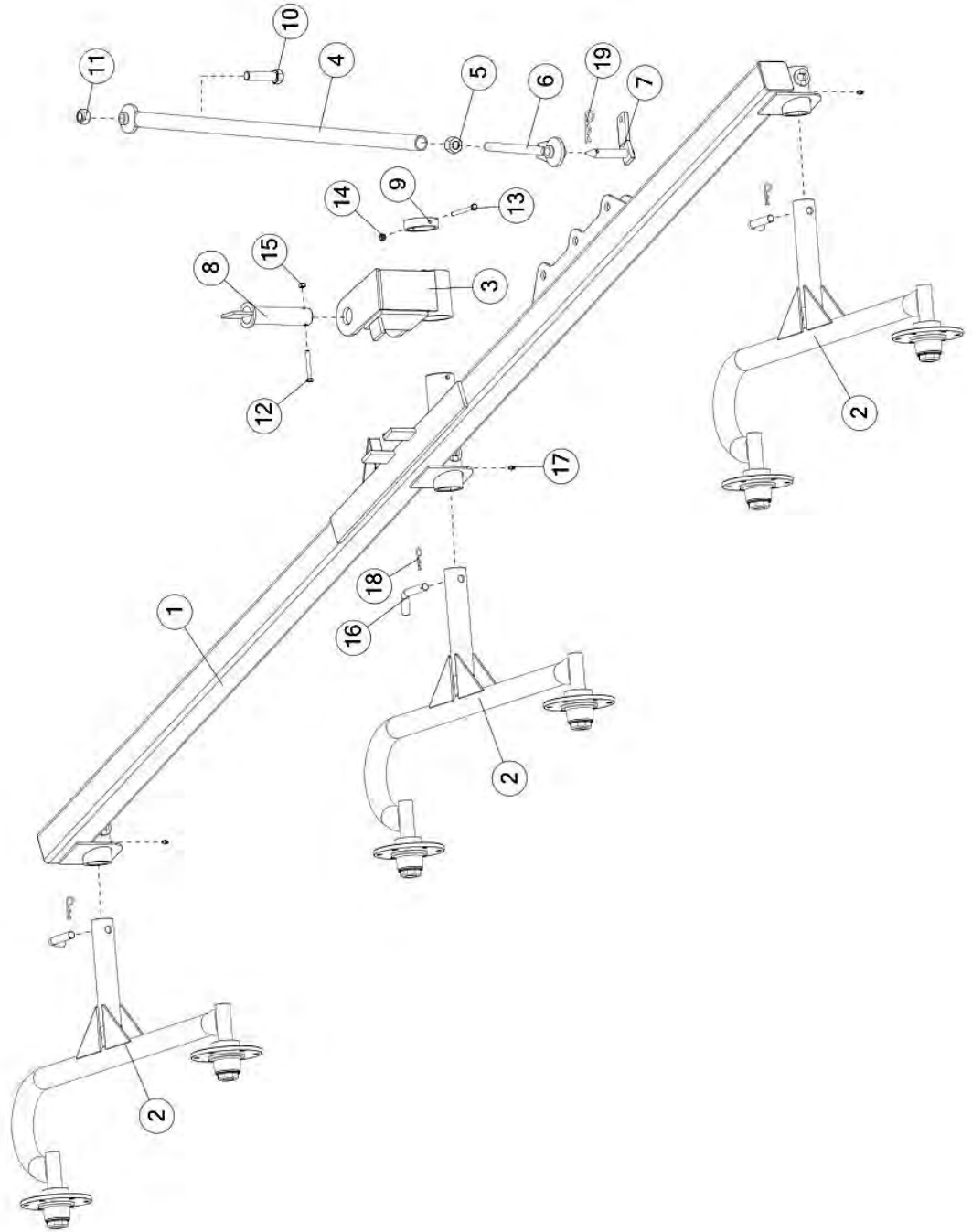

FIGURE 4

RAKE BEAM & COMPONENTS

<u>ITEM</u>	<u>QTY</u>	<u>PART #</u>	<u>DESCRIPTION</u>
1	1	12WR2	ASSY, RIGHT RAKE BEAM
*	1	12WR3	ASSY, LEFT RAKE BEAM
2	6	10WR22	RAKE ARM
3	1	10WR36	PIVOT BRACKET,RH
*	1	10WR37	PIVOT BRACKET,LH
4	2	10WR31	LINK ROD
5	2	YNAC24005	HEX NUT, ACME, 3/4-6
6	2	10WR9	ASSY, ADJUSTING ROD
7	2	BFR401	ASSY, CENTER SLIDER PIN
8	2	10WR6	ASSY, RAKE BEAM PIN
9	2	10WR8	PIVOT THRUST WASHER
10	2	YBHH24050	BOLT, 3/4-10 X 3 GR 5
11	2	YNL24005	HEX NUT, TOP LOCK, 3/4-10
12	2	YBHH10080	BOLT, 5/16"-18 X 2-1/2" GR 5
13	2	YBHH10110	BOLT, 5/16 X 3-1/2 GR 5
14	2	YNHX10005	HEX NUT, 5/16 GR 2
15	2	YNL10005	HEX NUT, TOP LOCK, 5/16-18
16	6	10WR13	CANE PIN
17	6	G89	ZERK, 1/4"-28
18	6	YPHR02005	HAIR PIN
19	2	YPHR02010	HAIR PIN.

***MEANS NOT SHOWN**

FIGURE 5
RAKE WHEEL ASSEMBLY

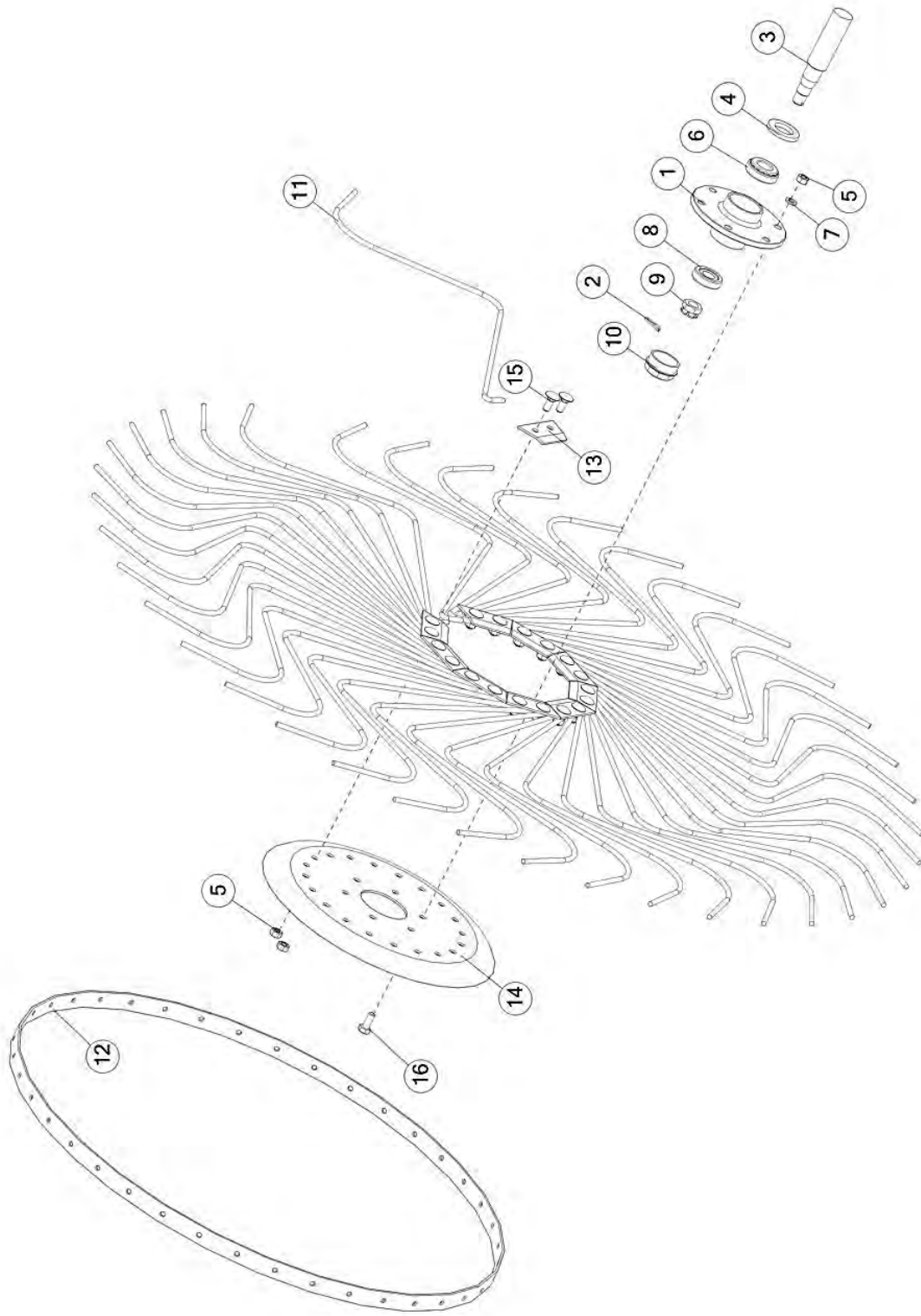

FIGURE 5

RAKE WHEEL ASSEMBLY

<u>ITEM</u>	<u>QTY</u>	<u>PART #</u>	<u>DESCRIPTION</u>
1	1	1086	HUB, RAKE WHEEL
2	1	1088	CLIP, RETAINING
3	1	BFR36	RAKE WHEEL SPINDLE
4	1	T163	SEAL, 2.05 X 1.25 X .25
5	26	YNHX76015	HEX NUT, M10-1.5
6	1	600012	BRG, 2.05 X 0.75, TAPER, COMPLETE
7	6	YWLO76015	WASHER, LOCK, M10
8	1	600014	BRG, 1.85 X 0.75, TAPER, COMPLETE
9	1	T172	NUT, HEX, 18MM - 1.5, CASTLE, G2, NF
10	1	T173	CAP, HUB, RAKE WHEEL
11	40	T176	RAKE WHEEL TOOTH
12	1	T177	RAKE WHEEL OUTER RING
13	10	T178	RAKE TOOTH CLIP
14	1	T179	RAKE WHEEL CENTER
15	20	YBCR76005	CARR. BOLT, 10MM X 25MM
16	6	YBHH76015	BOLT, M10-1.5 (25MM)

FIGURE 6
OPTIONAL - KICKER WHEEL



FIGURE 6

OPTIONAL - KICKER WHEEL

<u>ITEM</u>	<u>QTY</u>	<u>PART #</u>	<u>DESCRIPTION</u>
1	1	1086	HUB, RAKE WHEEL
2	1	1088	CLIP, RETAINING
3	40	10WR42	RAKE WHEEL TOOTH, 49", BLACK
4	1	BFR110	KICKER WHEEL SPRING
5	1	FR71	RAKE WHEEL CENTER 60 IN BLACK
6	10	FR74	RAKE TOOTH CLIP BLACK
7	1	T163	SEAL, 2.05 X 1.25 X .25
8	6	YWLO76015	WASHER, LOCK, M10
9	1	600012	BRG, 2.05 X 0.75, TAPER, COMPLETE
10	1	BFR36	RAKE WHEEL SPINDLE
11	1	600014	BRG, 1.85 X 0.75, TAPER, COMPLETE
12	1	T172	NUT, HEX, 18MM - 1.5, CASTLE, G2, NF
13	1	T173	CAP, HUB, RAKE WHEEL
14	1	T177A	OUTER RING FOR 48" RAKE WHEEL
15	1	10WR41	KICKER ARM
16	1	71625	WLDMNT, TOP MOUNTING BRACKET
17	1	71626	PLT, 10.50x6.00x.25, MOUNTING BRACKET, FRONT
18	1	10WR40	PIVOT MOUNT
19	1	10WR19	PULLEY MOUNT
20	1	BFR230	SPACER
21	1	BFR292	POLY PULLEY
22	2	ES14	THIMBLE
23	2	G16	BRONZE BUSHING 1-1/2"OD X 1-1/4"ID X 1.5"
24	1	G89	ZERK, 1/4"-28
25	2	S99	O-RING
26	1	ST81	EXTENSION SPACER, 11/16"
27	1	YBTE12005	TURNED EYE BOLT, 3/8-16 X 1" SHANK X 2-1/2" OAL
28	1	YMHK91005	MISC, S-HOOK 0.162 X 1-1/4
29	1	YMSN10005	MISC, SNAP HOOK, 5/16
30	1	BFR229	WASHER, SHIM .185x1.281 I.D.x2.00O.D.
31	1	YBTE12030	TURNED EYE BOLT, 3/8-16 X 3 SHANK TURNED
32	1	YPEX10015	EXPANSION PIN, 5/16" X 1-3/4"
33	1	10WR44	1/4" PROOF CHAIN 5-LINKS
34	20	YBCR76005	SCR, CARR, M10, 1.5, 25MM, 8.8, ZINC
35	1	YBHH10097	BOLT, 5/16-18 X 3 GR 5
36	1	YBHH12075	BOLT, 3/8"-16 X 2" GR 5
37	4	YBHH16030	BOLT, 1/2-13 X 1-1/2 GR 5
38	6	YBHH76015	SCR, HHC, M10, 1.5, 25MM, 10.9, ZC
39	1	YNHX10005	HEX NUT, 5/16 GR 2
40	1	YNHX12005	HEX NUT, 3/8"-16, GR. 2
41	4	YNHX16005	HEX NUT, 1/2"-13 GR. 2
42	26	YNHX76015	NUT, HEX, M10-1.5, NA, CL10, ZC
43	1	YWFL12005	WASHER, FLAT, 3/8 USS
44	1	YWLO10005	WASHER, LOCK, 5/16
45	1	YWLO12005	WASHER, LOCK, 3/8
46	4	YWLO16005	WASHER, LOCK, 1/2"

FIGURE 7 HYDRAULICS

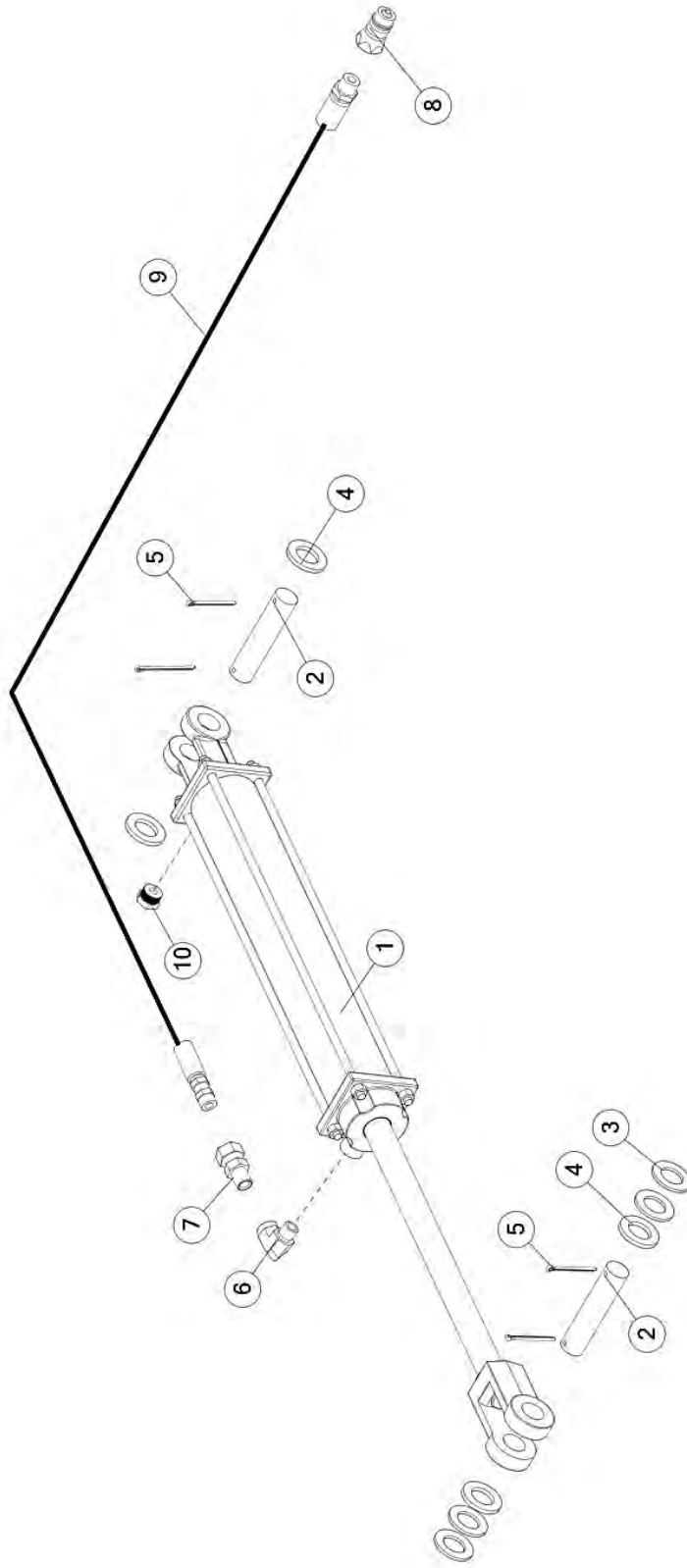

FIGURE 7

HYDRAULICS

<u>ITEM</u>	<u>QTY</u>	<u>PART #</u>	<u>DESCRIPTION</u>
1	1	56007	2.5" X 16" HYDRAULIC CYLINDER
2	2	LW55	PIN, 1.00 X 4.50, CYLINDER
3	2	16SV136	WASH, FLAT, 1.75 X 1.02 X 0.13, ZC
4	6	BFR33	WASHER
5	4	YPCT05025	COTTER PIN, 5/32 X 2
6	1	23N234	ELBOW, STREET, 3/8", 90 DEGREE # 5502-6-6
7	1	58723	3/8 MALE ADPTER WITH .062 ORIFICE
8	1	DWM205	MALE QUICK COUPLER
9	1	10WR10	HOSE, 3/8" X 145"
10	1	BFR70	VENT PLUG 3/8"

FIGURE 8

HYDRAULIC CYLINDER

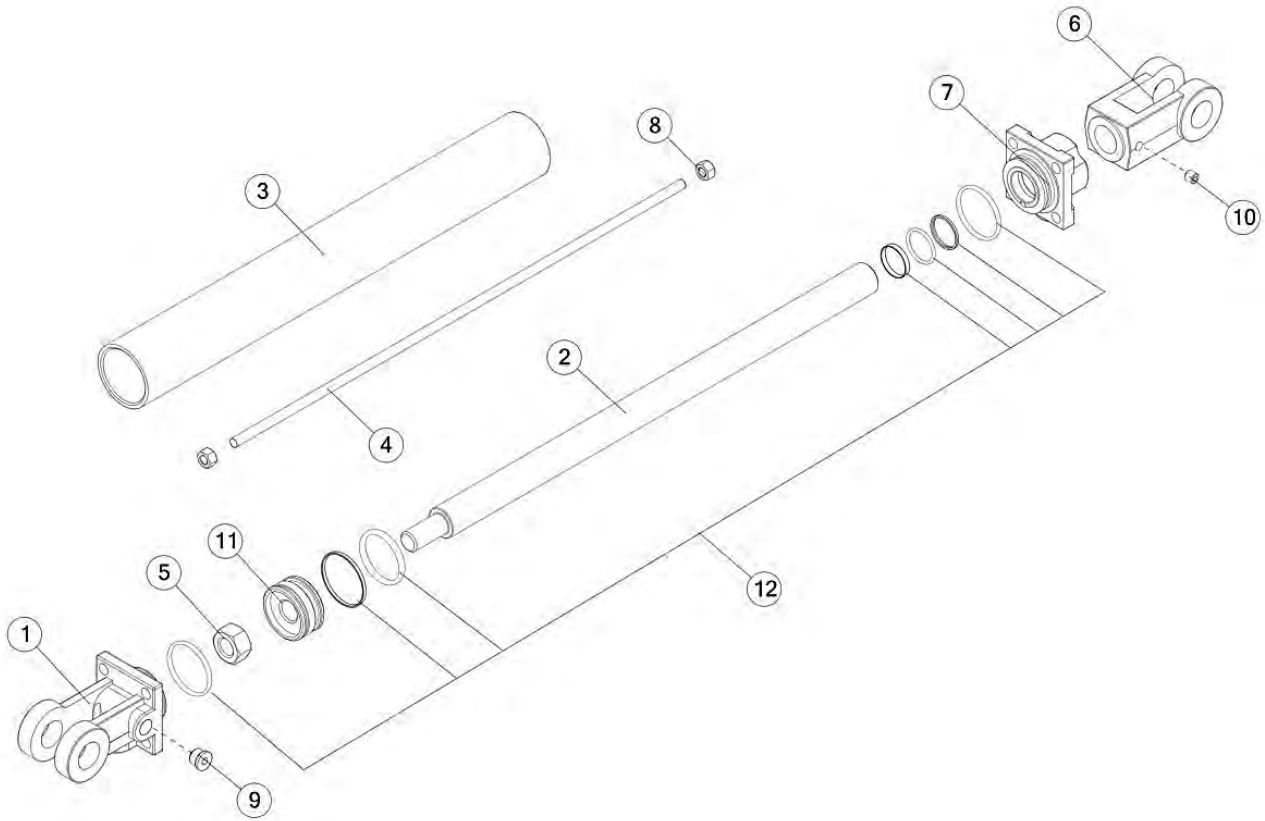
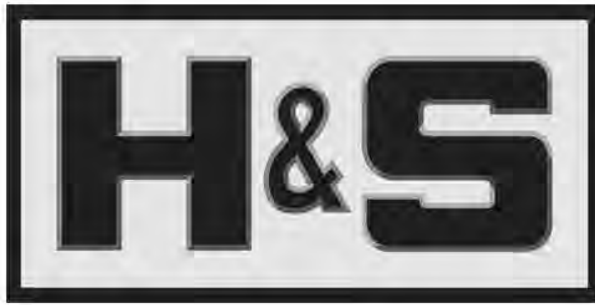

FIGURE 8

HYDRAULIC CYLINDER

<u>ITEM</u>	<u>QTY</u>	<u>PART #</u>	<u>DESCRIPTION</u>
1	1	66932	CLEVIS CAP FOR 2" CYLINDER
2	1	72237	ROD
3	1	72234	CYL. TUBE
4	4	72236	SHAFT, RND
5	1	23N148	PISTON NUT
6	1	23N150A	ROD CLEVIS
7	1	66934	ROD CAP FOR 2" CYLINDERS
8	8	YNHX12005	HEX NUT, 3/8-16 GR 2
9	1	SD270	HOLLOW HEX PLUG 6
10	1	YSSO12015	SET SCREW, SOCKET, 3/8-24 X 3/8
11	1	56182	PISTON FOR 3" CYLINDER
12	1	56187	SEAL KIT FOR 2" CYLINDER



**H&S Manufacturing products are approved for the
FEMA SEAL OF QUALITY**

**P.O. BOX 768, MARSHFIELD, WI 54449
(715) 387-3414 FAX (715) 384-5463
www.hsmfgco.com**